

CAUTION: The final determination as to the suitability of this product for any purpose is solely that of the user. Columbia products are not to be used to lift people or to lift anything over people.

### DIMENSIONAL DATA

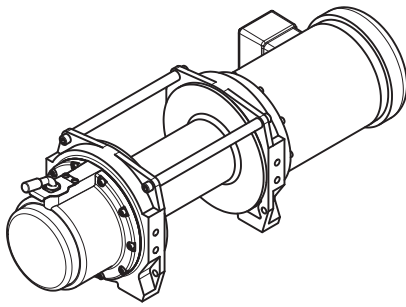
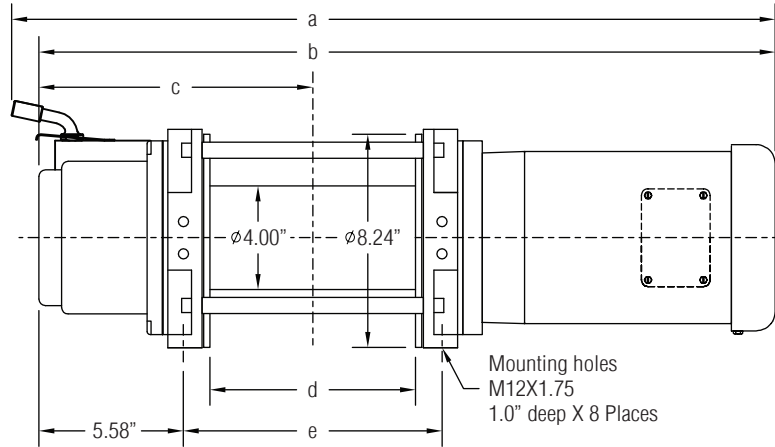
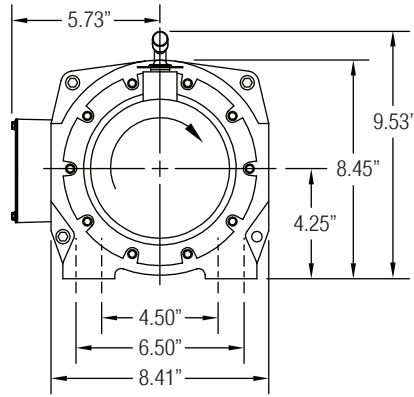

Drum Size	Dimensions					Typical Weight	Wire Rope Capacity		
	a <sup>1</sup>	b <sup>1</sup>	c	d	e		1/4"	5/16"	3/8"
01	28.4"	27.3"	10.57"	8.0"	10.0"	122 lbs	326'	228'	159'
02	30.4"	29.3"	11.57"	10.0"	12.0"	125 lbs	407'	285'	198'
03	32.9"	31.8"	12.82"	12.5"	14.5"	135 lbs	509'	356'	248'

<sup>1</sup> Dimension for 1.5 HP 3Ø 1750 RPM motor shown

### PERFORMANCE

Model	Motor		Power Input		Gear Ratio	Calculated Performance					
	HP	RPM	Voltage	Ø		First Layer		Mean Drum		Full Drum	
						LBS	FPM	LBS	FPM	LBS	FPM
WF375	1.0	1700	115/230	1Ø	27:1	375	74.2	281	96.3	229	118.3
			230/460	3Ø							
WF575	1.5	1700	230	1Ø	27:1	575	74.2	421	96.3	343	118.3
			230/460	3Ø							
WF775	2.0	1700	230/460	3Ø	27:1	775	74.2	562	96.3	457	118.3
WF1000	1.0	3300	115/230	1Ø	164:1	1,000	24.1	780	31.2	635	38.4
			230/460	3Ø							
WF1500	1.5	3300	115/230	1Ø	164:1	1,500	24.1	1,171	31.2	953	38.4
			230/460	3Ø							
WF2100	2.0	3300	230	1Ø	164:1	2,100	24.1	1,561	31.2	1,270	38.4
			230/460	3Ø							
WF3100	3.0	3300	230/460	3Ø	164:1	3,100	24.1	2,341	31.2	1,905	38.4
WF2300	1.0	1725	115/230	1Ø	164:1	2,300	12.2	1,769	15.9	1,439	19.5
			230/460	3Ø							
WF3500	1.5	1725	115/230	1Ø	164:1	3,500	12.2	2,653	15.9	2,159	19.5
			230/460	3Ø							
WF4700	2.0	1725	230	1Ø	164:1	4,700	12.2	3,538	15.9	2,879	19.5
			230/460	3Ø							
WF7000	3.0	1725	230/460	3Ø	164:1	7,000	12.2	5,307	15.9	4,318	19.5

Performance based on intermittent duty cycles.

Columbia winches and hoists are available for AC, DC, hydraulic or pneumatic power sources. Special models for any application can be supplied - please contact your distributor for details.

Distributed by:

**ALLIED POWER PRODUCTS, INC.**

**THE WINCH & HOIST SPECIALISTS**

6590 SW Fallbrook Place, Beaverton, OR 97008

(503) 626-0654 Fax (503) 646-1996

www.alliedpower.com