

NOTES

- ① Minimum flange width; see table for acceptable range of I-beam width.
- ② Dimension varies with flange width; shown with S10X25.4 I-beam.
- ③ Dimension varies with flange thickness; shown with S10X25.4 I-beam.
- ④ Dimension when fallblock is fully raised.
- 5. Compatible with all standard and most wide flange beams.

Working Load	Wire Rope Sizes	Minimum Beam Height	I-Beam Width	Net Weight (Approx)
15,000 lbs.	7/16" or 1/2"	10.0"	4.6"-10.3"	500 lbs.

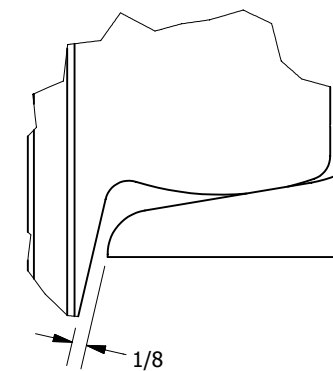

DETAIL A

ADJUSTMENT ILLUSTRATION & INSTRUCTIONS
 The correct trolley setting is the beam flange width plus approximately 1/8" running clearance on each side of the flange; the clearance should not exceed 5/16".

Move the spacing washers on either side of the trolley side plates to adjust as required.

After adjustment, tighten the trolley pin nuts and locking nuts securely.