

Frame 2 AC Electric Hoist

Parts Breakdown

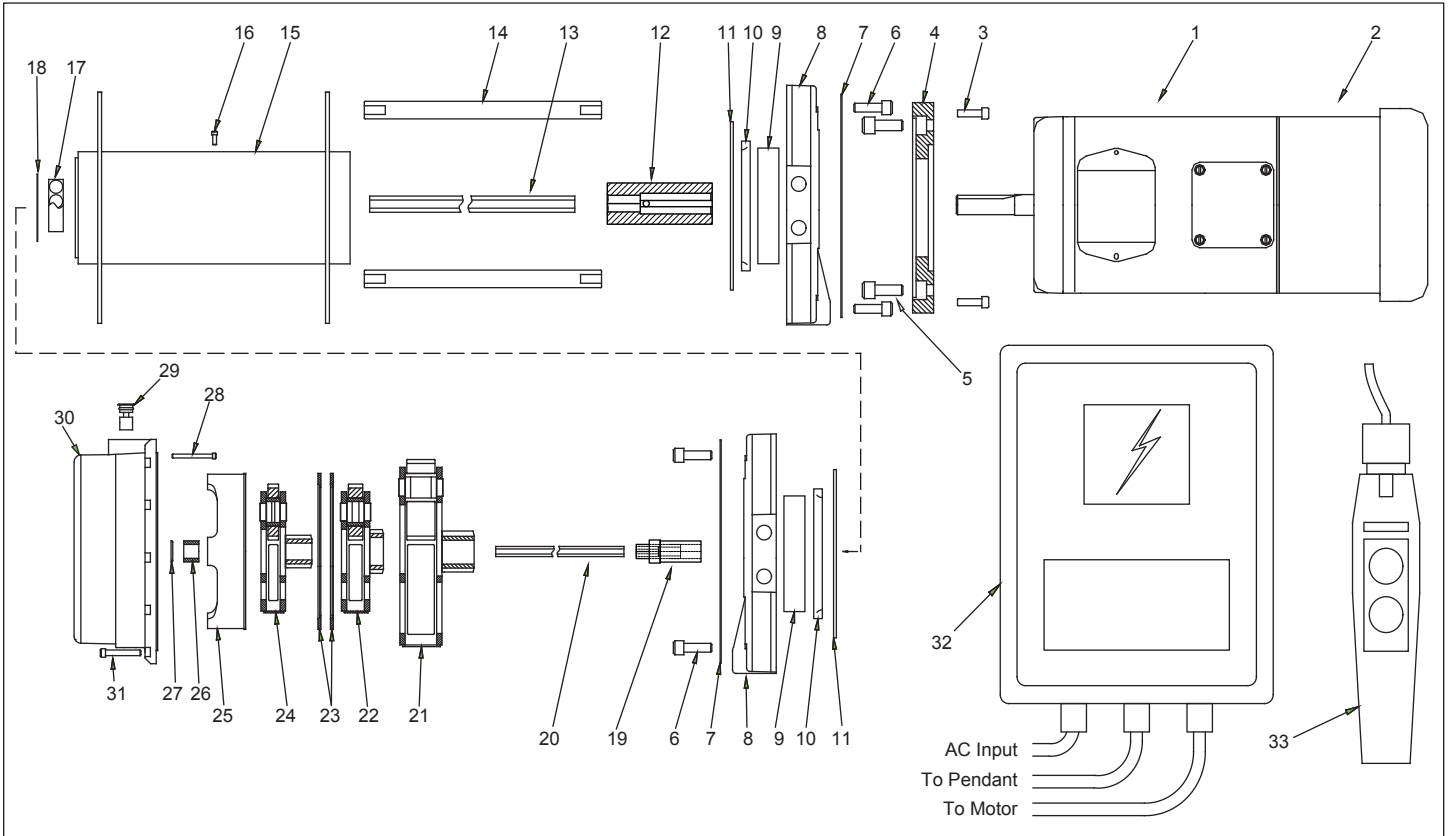

Parts List

HF4700-4A34-L-03

Item	Part Number	Qty	Description	Item	Part Number	Qty	Description
1	DFT90S2BMHR	1	Brakemotor	21	30310	1	3rd Stage Carrier
2	-----	--	-----	22	18598	1	2nd Stage Carrier
3	-----	10	1/4-20 x 1-1/4" SHCS	23	15581	2	Retaining Ring
4	MC1065	1	Motor Adapter	24	15654	1	1st Stage Carrier
5	-----	4	3/8-16 x 3/4" SHCS	25	34837	1	Clutch Gear
6	-----	6	3/8-16 x 1-1/4" SHCS	26	19574	1	Sun Gear
7	14964	2	Gasket	27	64252	1	Thrust Plug
8	31675	2	Drum Support	28	36634	1	Clutch Retainer
9	30274	2	Drum Bushing	29	23667	1	Freespool Blockout
10	30275	2	Seal	30	31676	1	Gear Housing Assembly
11	30277	2	Thrust Washer	31	-----	10	1/4-20 x 1-1/4" SHCS
12	MC1224	1	Coupler	32	MC1008A	1	Control Box
13	MC1240	1	1/2" hex drive	33	MC1230	1	Low-Voltage Pendant
14	31288	3	Tie Rod				
15	32225	1	Drum				
16	36974	1	Set Screw				
17	31672	1	Ball Bearing				
18	3000-X187	1	Snap Ring				
19	MC1225	1	Adapter				
20	MC1226	1	5/16" hex drive				